

### IMPORTANT NOTE:

Read and understand these instructions before installing, operating, or maintaining this equipment.

The product is designed to be a component of a customised safety orientated control system. It is the responsibility of each manufacturer to ensure the correct overall functionality of its systems and machines. IDEM, its subsidiaries and affiliates, are not in a position to guarantee all of the characteristics of a given system or product not designed by IDEM.

### APPLICATION:

Coded Non Contact switches are designed to interlock hinged, sliding or removal guard doors. They are specifically advantageous when:

- poor guard alignment exists
- anti-tamper is required
- high hygiene requirements exist e.g. food industry hose down
- a long mechanical life is required (no moving or touching parts).

The PSA/MSA Coded Non Contact Switches can be used to provide protection up to Category 4 and Plc to ISO13849-1.

### OPERATION:

All Coded Non Contact Safety Switches are designed to conform to EN60947-5-3 (PDF-M) and be used as directed by EN1088, EN ISO12100 and EN 60204-1. They have coded magnetic sensing which provides a wide (>10mm) sensing distance and provides a high tolerance to misalignment after sensing. They can be fitted behind stainless steel fittings and can operate in extreme environments of temperature and moisture.

### INSTALLATION:

Installation of all Coded Non Contact Switches must be in accordance with a risk assessment for the individual application.

The PSA/MSA internally monitor 2 redundant circuits as per ISO13849-1 for up to Plc/Category 4 protection.

M4 mounting bolts must be used to fix the switches. Tightening torque for mounting bolts to ensure reliable fixing is 1.0 Nm. Always mount on to Non Ferrous materials.

The recommended setting gap is 5mm. The Safety switch must not be used as a mechanical stop or be adjusted by striking with a hammer.

The actuator must not be allowed to strike the switch. Do not mount adjacent switches or actuators closer than 30mm.

Typical misalignment tolerance after setting is 5mm.

After installation always check each switch function by opening and closing each guard individually in turn and ensuring that the Green LED on the switch and the LED's on the Safety Relay are illuminated when the switch is closed and are extinguished when the switch is open. Check that the machine stops and cannot be re-started when each switch is open.

### ACTUATOR OPENING DIRECTIONS:

Align actuator and switch using the target lines.

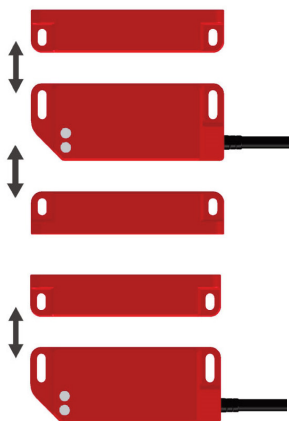

### DIMENSIONS:

All dimensions in mm.

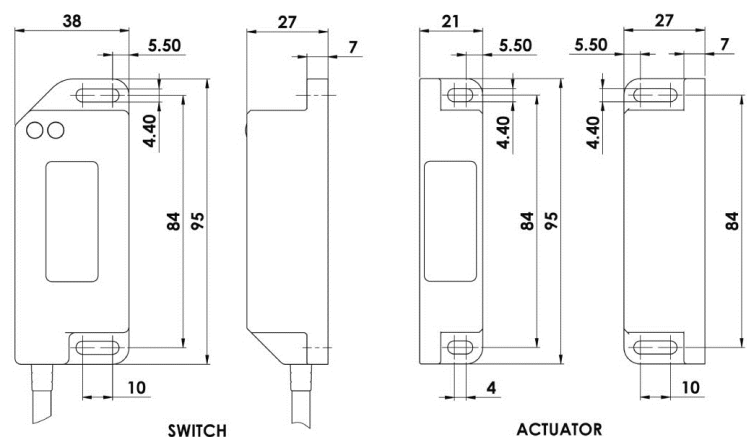

### MAINTENANCE:

Weekly: Check alignment of actuator and look for signs of mechanical damage to the switch casing. Check wiring for signs of damage.

Monthly: Check each switch function by opening and closing each guard individually in turn and ensuring that the Green LED on the switch is illuminated when the switch is closed and extinguished when the switch is open. Check that the machine stops and cannot be re-started when each switch is open.

Never repair any switch, actuator or integral cables. Replace any switch displaying signs of mechanical damage to the casing or cables.

# Non Contact Stand Alone Coded Safety Switches

## CONNECTION EXAMPLE: Switches in series PLe Cat.4

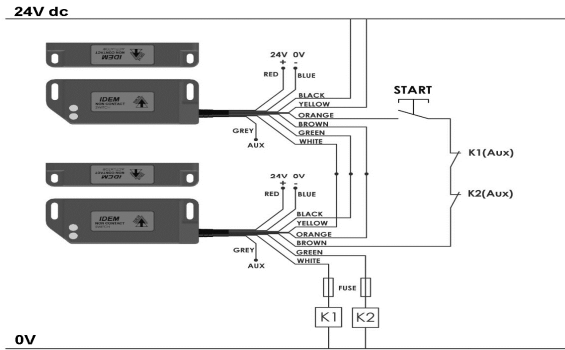

Two switches connected in series to give dual circuit safety outputs to machine contactors.

Safety Circuit 1 (Black/White) utilises internally checked force guided relay contacts and is connected in series with the corresponding Safety Circuit 2 (Yellow/Green) of the next switch.

Allows minimal wiring and higher current switching to K1 and K2 contactors.

A manual start and contactor feedback check is achieved by connecting K1 (Aux) and K2(Aux) feedback contacts and momentary start button through the orange and brown feedback check.

**Standards:** EN1088 IEC60947-5-3 IEC60947-5-1 EN60204-1 ISO13849-1 EN62061 EN954-1 UL508

### Safety Classification and Reliability Data:

Power Supply	24Vdc +/-10% (Consumption 150mA max.)
Safety Output Maximum Rating	240V 3A ac/dc
Auxiliary Output Maximum Rating	24Vdc 0.5A
Dielectric Withstand	4k Vac
Insulator Resistant	100 Mohms
Recommended Setting Gap	5mm
Switching Distance (Target to Time)	Sao 10mm Close Sar 15mm Open
Tolerance to Misalignment	5mm in any direction from 5mm setting gap
Approach Speed	600mm/m to 1000mm/s
Body Material	PSA High Specification Polyester MSA Stainless Steel 316
Temperature	-25C/45C
Shock Resistance	IEC 68-2-27 11ms 30g
Vibration Resistance	IEC 68-2-6 10-55Hz 1mm
Enclosure Protection	PSA: IP67 MSA: IP69K/IP67
Cable Type	PVC 10 core 7mm OD
Mounting Bolts	2 x M4

Quick Connect (QC) Flying Lead 250mm M12 8 way Male Plug (Pin view from switch)	Flying Lead Colours	Circuit	
2	Red	Supply +24Vdc	24Vdc +/- 10%
3	Blue	Supply 0Vdc	
1	White	Safety Output 1 (Force guided relay)	AC15 250Vac 3A
7	Black	Safety Output 1 (Force guided relay)	DC13 24Vdc 3A
4	Yellow	Safety Output 2	AC15 250Vac 3A
6	Green	Safety Output 2	DC13 24Vdc 3A
8	Brown	Reset/Check Circuit – Output	
Not Used	Orange	Reset/Check Circuit – Manual start	
5	Pink	Reset/Check Circuit – Auto start	
Not Used	Grey	Auxiliary Feed	Electronic +24Vdc 0.5A

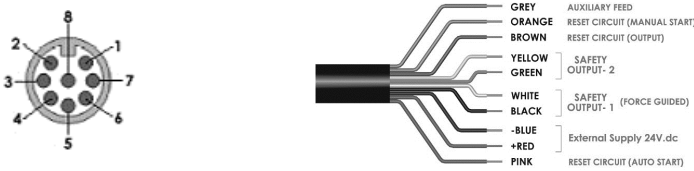

### Characteristic Data according to IEC62061 (used as a sub system)

Safety Integrity Level	SIL3	
PFH (1/h)	3.95E-10	Corresponds to 4.0% of SIL3
PFD	3.46E-05	Corresponds to 3.5% of SIL3
Proof Test Interval T <sub>1</sub>	20a	

### Characteristic Data according to EN ISO13849-1

Performance Level	E	
Category	Cat4	
MTTF <sub>d</sub>	446a	
Diagnostic Coverage DC	99% (high)	

The calculation of the above values is based on the following assumptions:

Number of operating days per year:  $d_{op} = 365d$   
 Number of operating hours per day:  $h_{op} = 24h$   
 Number of operating cycles per day:  $n_{cyc} = 1/d$   
 $B10_d = 150,000$  AC1 Load 3A  
 $= 2,000,000$  AC1 Load 0.5A

When the product is used deviant from these assumptions (different load, operating frequency, etc.) the values have to be adjusted accordingly.

### SAFETY PRECAUTIONS:

1. Installation and commissioning of the device must be performed **only by authorised personnel**.
2. Observe the country specific regulations when installing the device.
3. The wiring of the device must comply with the instructions in this user information - otherwise there is a risk that the safety function will be lost.
4. External fusing of the safety contacts (a slow blow or 6A quick action must be provided).
5. All relevant safety regulations and standards are to be observed.
6. The overall concept of the control system in which the device is incorporated must be validated by the user.
7. Failure to observe the safety regulations can result in death, serious injury and serious damage.
8. Always use Safety Output 1.

To request this data sheet in other languages please contact [info@idemsafety.com](mailto:info@idemsafety.com).  
 Um dieses Datenblatt in Deutscher Sprache wenden Sie sich bitte anfordern [info@idemsafety.com](mailto:info@idemsafety.com).  
 Pour obtenir cette fiche en Français, veuillez contacter [info@idemsafety.com](mailto:info@idemsafety.com).  
 Para solicitar esta hoja de datos en Español, por favor contacto con [info@idemsafety.com](mailto:info@idemsafety.com).

## CE EC Declaration of Conformity

**MANUFACTURER:** IDEM SAFETY SWITCHES LIMITED  
 Hindley Industrial Estate, Hindley Green, Wigan, Lancashire WN2 4HR, United Kingdom

**THE LISTED DEVICES CONFORM TO THE ESSENTIAL HEALTH AND SAFETY REQUIREMENTS OF THE FOLLOWING EUROPEAN DIRECTIVES AND STANDARDS:**

Machinery Directive (2006/42/EC)  
 Low Voltage Directive (2006/95/EC)

**DEVICES: NON CONTACT SAFETY SWITCHES:**

PSA MSA Standalone Coded Safety Switches

**STANDARDS (plus amendments):**

EN 60947-5-2: 2007  
 EN 60947-5-3 1999 + A1:2005  
 EN ISO 13849-1: 2008

**M. Mohtasham** Managing Director  
 1<sup>st</sup> May 2013